



# Vehicle Tracking System

## Installation Guide

**Note to Installer** - Please return these instructions to customer for future reference  
**Installation Support:**  
**+91-8888300004**  
**sales@satcop.com**

### **Precautions**

#### **12v DC Power only.**

The Vehicle Tracking System (VTS) is designed for negative ground 12V DC systems only. Do not use the VTS with any other power systems.

#### **Do not disassemble or modify the VTS.**

This could cause electric shock, personal injury or fire. Do not connect power from a different system to the VTS. When in doubt of a safe installation, please contact your local installer.

#### **Do not install VTS in locations that interfere with airbag operation.**

This could cause a risk of accidents and injury.

### **Cautions**

- a. Do not let wires get punctured by screws or caught in moving parts.
- b. Turn vehicle ignition off before making connections.
- c. Connect the Red power input lead after all other connections have been made.
- d. Use a common ground point for all ground wires.
- e. Tape and insulate any loose unconnected wires.

### **Note on power wire (Red)**

When connecting VTS in combination with other electric devices, be sure the vehicles' circuit amp rating is higher than the sum of each component's fuse.

## Installation

Installation of your VTS devices is as easy as it gets – just follow these three steps:

1. Plug the power wiring harness into the device
2. Plug the antenna (with the embossed letters “GPS” facing UP) on your dashboard at the base of the windshield.
3. Run the cables along the side of the dashboard at the door hinge and place the device under your dashboard. For best results, consider using zip-tie to secure the device to ensure it doesn't fall from beneath the dashboard.

Securely attach the wiring harness to the device.  
Connect the following wires:

Red	12 VDC Constant
Black	Ground
Green	Ignition
Yellow	Relay
Green	Not in use
Blue	Analog Input
White	Digital Input (For AC)
Orange	Digital Output
Grey	SOS(Gnd)
Pink	SOS+

## Covert Installation

Many clients prefer the device installed where the antenna & device are hidden from view.  
The antenna of the device can be placed under the dashboard of most vehicles and trucks.

## Proper Device Placement

While installation of our VTS is a simple three step process, the fact remains that proper antenna placement is crucial to uninterrupted operation.

A good installation location for the antenna should typically have visibility to 14 satellites at peak. If the antenna is installed in a location which only has visibility to a maximum of 9 satellites at peak, problem may occur which will result in intermittent operations.

So, remember metal causes problems for GPS antenna. As a result, placement of the antenna in a position which might be slightly obscured by metal – including wires, wiper blades, window tint or aluminium foil – may compromise antenna visibility of the GPS satellite constellation.

Proper antenna placement – Base of the windshield, no metal obstructions (windshield wipers, wires, etc).

**Note:** We strongly recommend getting your power directly off the ignition column – Most vehicles have constant power there

**Note:** GPS signal will penetrate glass, plastic, form, fiberglass and wood. **GPS signal will NOT penetrate metal**, for this reason it is important to place the device with no metal or wiring between it and the sky.

## Wiring diagram

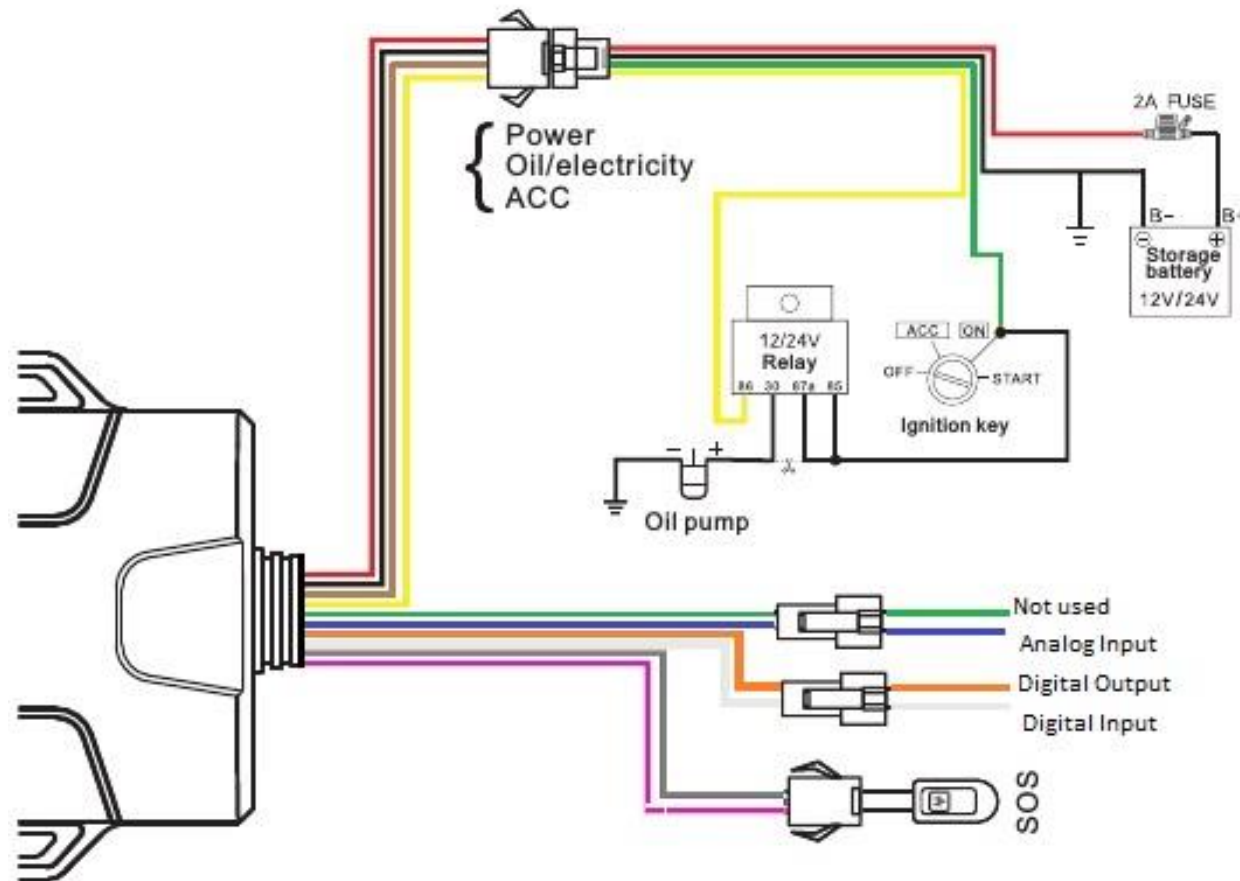

Note:

1. While installing on two-wheeler make sure you connect the red wire of the harness with ignition wire instead to the battery positive directly.

## Device Specifications

GPS antenna connector	In-build
GSM antenna connector	In-build
Power connector	4-pin molex

## ELECTRICAL SPECIFICATIONS

Operating Voltage	9 to 36 VDC
Power Consumption	
Operating	<100 mA @ 12V DC
Standby	10 mA @ 12V DC

## ENVIRONMENTAL SPECIFICATIONS

Operating	-20°C to 80°C
Humidity	5 to 90%
Vibration	9.8 m/s <sup>2</sup>
EMC/EMI	ISO7637-2 (Pulse 1-5A)

## GPS TECHNOLOGY

GPS	22 channel (Tracking)
Sensitivity	-165 dBm (Tracking)
Navigation	-165 dBm
Horizontal accuracy	<2.5m CEP
Time-to-first-fix	<15s (@ -148 dBm)

## Installation Best Practices

Power for the device should be taken directly from the ignition column.

There you will find constant power. This is the cleanest source of power for the device.

As much as possible, keep all device wires away from speakers and speaker wires, as well as high powered electrical components.

Do not use the radio as a source of power for any of the power leads to the device, interference may result.

Secure device with zip-tie or other strapping – so it will not move around.

## Technical Support

Please contact +91-8888300004, Monday to Saturday from 09:30 am – 6:30 pm IST.

## Troubleshooting Guide

If installed too far below the dashboard, the device may still function in areas where strong wireless data coverage is available. Despite the fact it functions, such poor antenna placement may deteriorate signal quality from 5 bars to only 2 bars (hypothetically). Similarly, in an area where wireless coverage provides only 3 bars of service, your device would be unable to communicate due to signal deterioration based on poor antenna placement.

It is for this reason that a quality install and good antenna placement is critical.

## Common Problems

**a. The map shows my vehicle to be stopped, but the vehicle is moving.**

**Answer:** This caused by either of two potential issues:

1. The device is not transmitting
  - a. Poor wireless data coverage
  - b. Poor antenna location resulting in deteriorated wireless data signal.
  - c. Antenna not plugged into the device.
2. The GPS unit cannot see the sky.
  - a. Antenna facing downward.
  - b. Poor antenna placement.
  - c. Antenna is placed too far below the dash to have a good view of the sky.
  - d. On a new install, it may take several minutes for the GPS to establish location.

**2. The system shows my vehicle to be hundred meters from its actual location.**

**Answer:** The GPS unit does not have a good view of the sky.

- a. When the vehicles are parked facing tall buildings (or in indoor garages or under metal awnings) large portions of the sky are often obscured.
- b. Antenna placement is critical to ensure reliable and accurate operation.

**3. I logged in, and I get is map of India. My vehicle doesn't show.**

**Answer:** In almost every case, this is because it's a newly installed device and the unit hasn't yet transmitted its first packet of data (and thus cannot appear on the map because we don't yet know its location). It generally takes approx. 5 minutes after a new device has been powered up to begin transmitting.